

OUTLINE DRAWING

CODE: D 10031 Rev.:00

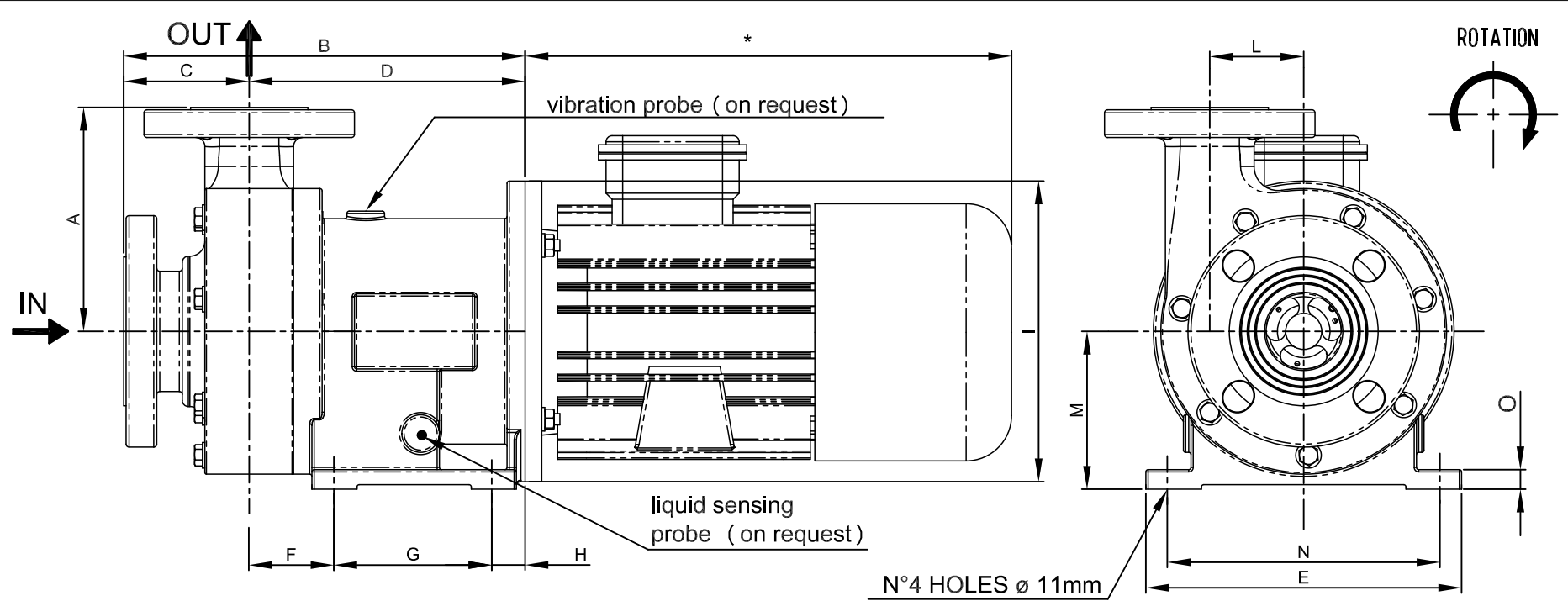

DIMENSIONS

A	B	C	D	E	F	G	H	I	L	M	N	O
128	217	75.5	141.5	170	42.5	80	19	160	53	85	140	12

- This drawing is for reference only
 - Pump may be supplied without motor
 - All dimensions are in millimeters

* Depend on the manufacturer

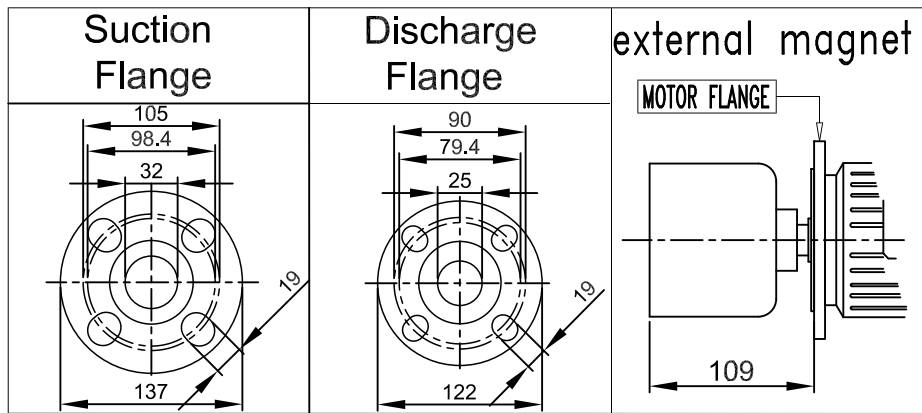

ITEM:
 Pump model: C MAG-P32 PP/PVDF

Motor: IEC Gr71 B5
 Port connection: Universal Flange

OUTLINE DRAWING

CODE: D 10196 Rev.:00

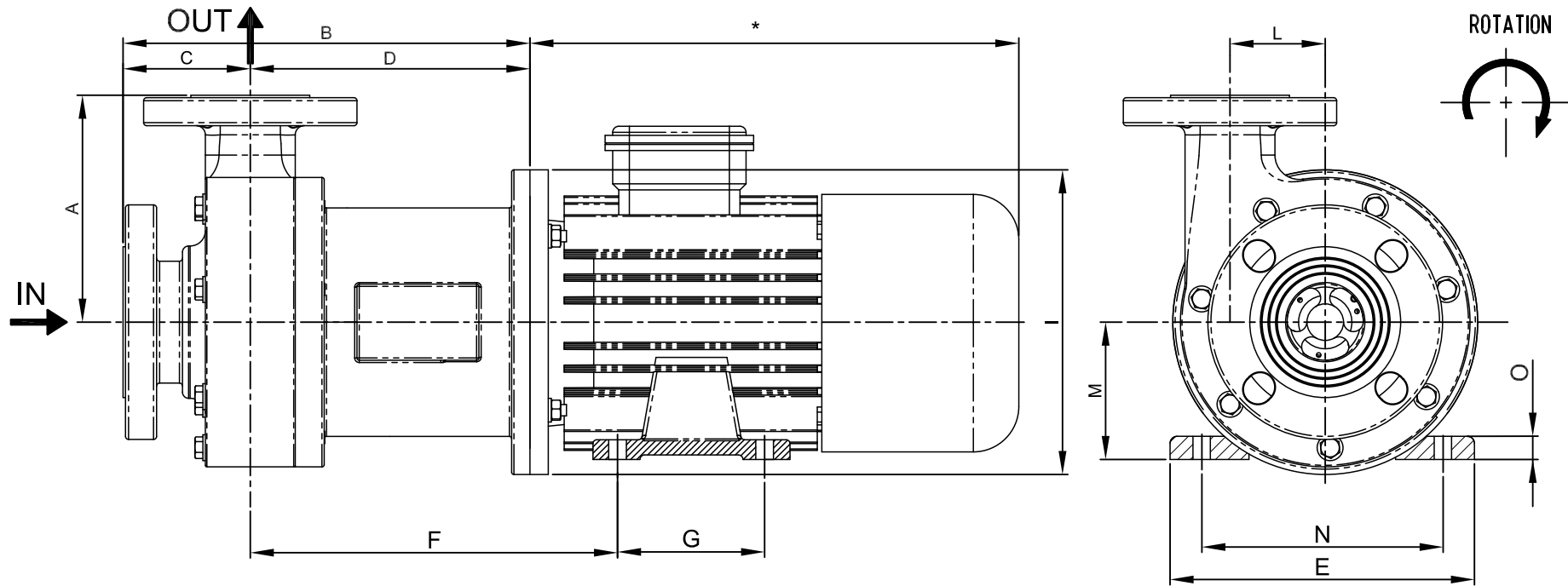

ITEM: Pump model: C MAG-P32 PP/PVDF

DIMENSIONS

A	B	C	D	E	F	G	I	L	M	N	O
128	217	75.5	141.5	140	186.5	90	160	53	71	112	7

- This drawing is for reference only
- Pump may be supplied without motor
- All dimensions are in millimeters

* Depend on the manufacturer

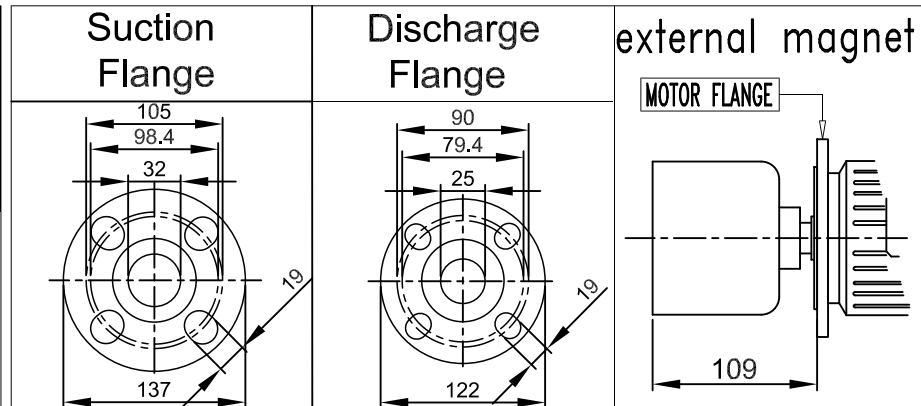

Motor: IEC Gr71 B3-B5
Port connection: Universal Flanged

OUTLINE DRAWING

CODE: D 10021 Rev.:00

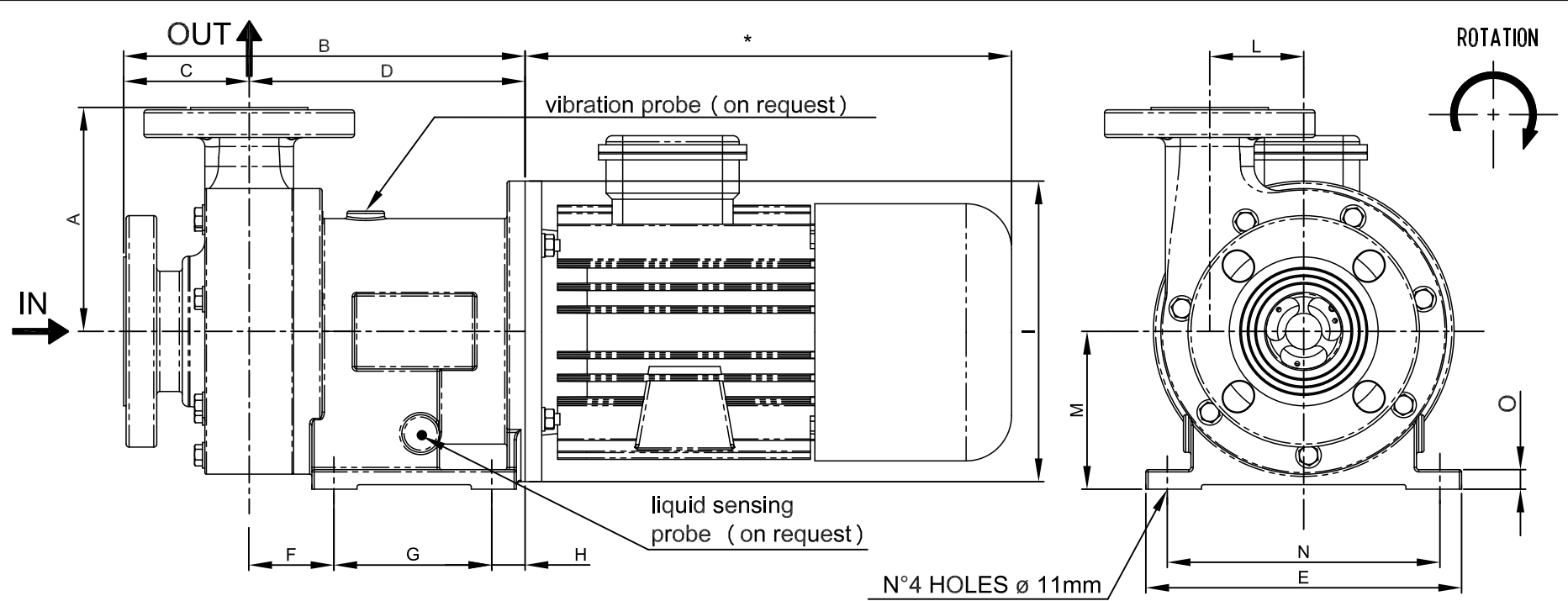

DIMENSIONS

A	B	C	D	E	F	G	H	I	L	M	N	O
141	235	84.5	150.5	195	45.5	85	20	200	58.5	103	165	13

- This drawing is for reference only
 - Pump may be supplied without motor
 - All dimensions are in millimeters

* Depend on the manufacturer

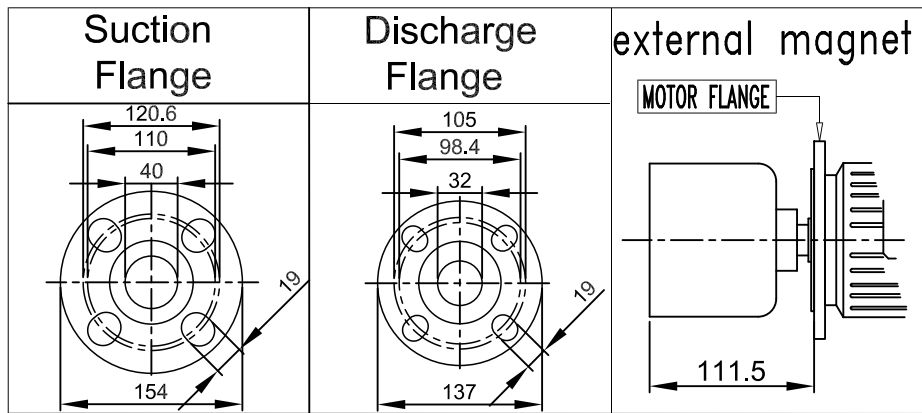

ITEM: Pump model: C MAG-240 PP/PVDF

Motor: IEC Gr80 B5
 Port connection: Universal Flanged

OUTLINE DRAWING

CODE: D 10059 Rev.:00

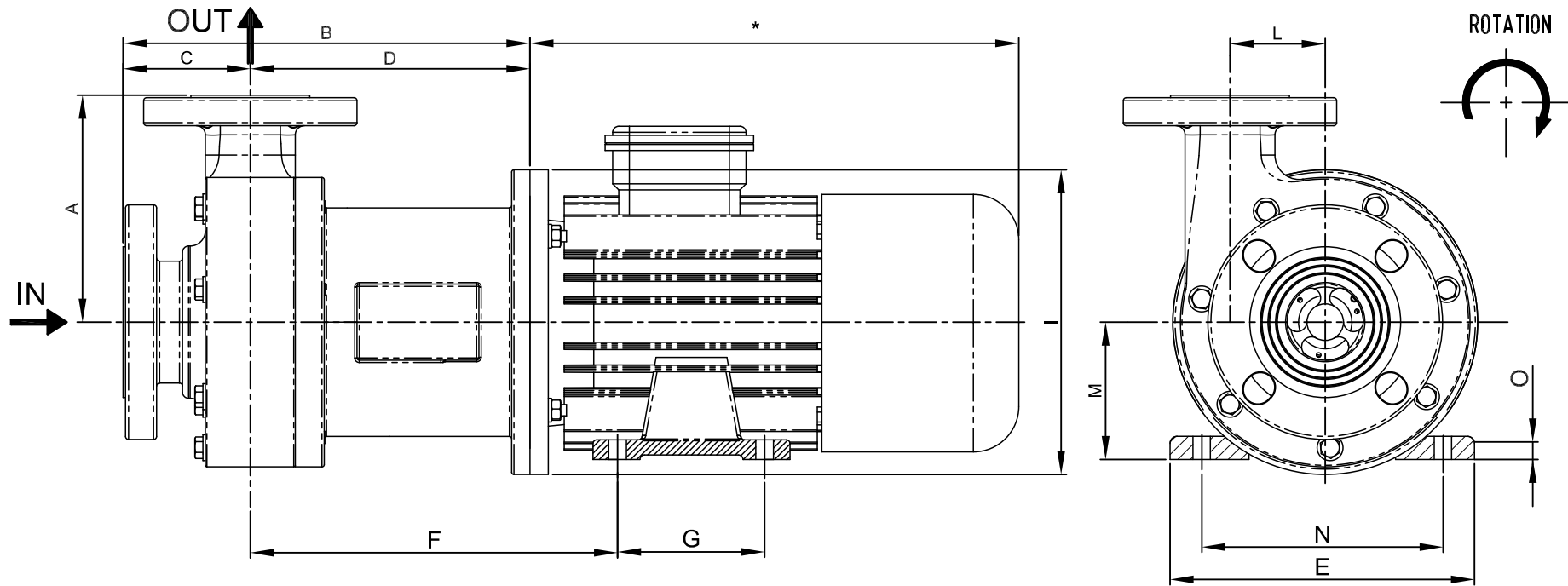

ITEM: Pump model: C MAG-P40 PP/PVDF

DIMENSIONS

A	B	C	D	E	F	G	I	L	M	N	O
141	235	84.5	150.5	160	200	100	200	58.5	80	125	11

- This drawing is for reference only
- Pump may be supplied without motor
- All dimensions are in millimeters

* Depend on the manufacturer

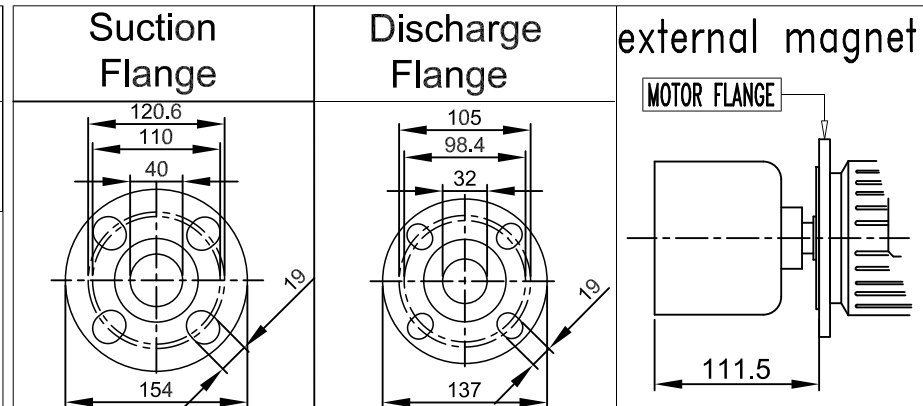

Motor: IEC Gr80 B3-B5
Port connection: Universal Flanged

OUTLINE DRAWING

CODE: D 10010 Rev.:00

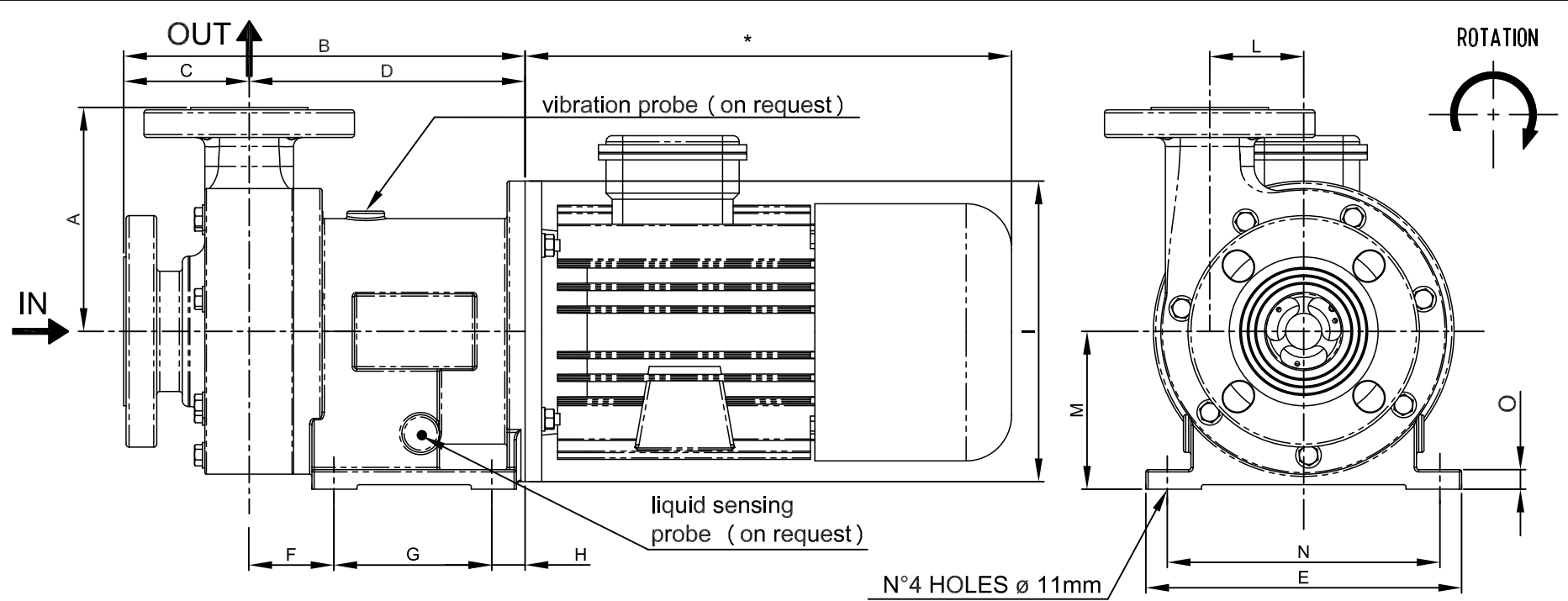

DIMENSIONS

A	B	C	D	E	F	G	H	I	L	M	N	O
149	267	83.5	183.5	210	56.7	106	20.8	200	62.5	105	180	13

- This drawing is for reference only
- Pump may be supplied without motor
- All dimensions are in millimeters

* Depend on the manufacturer

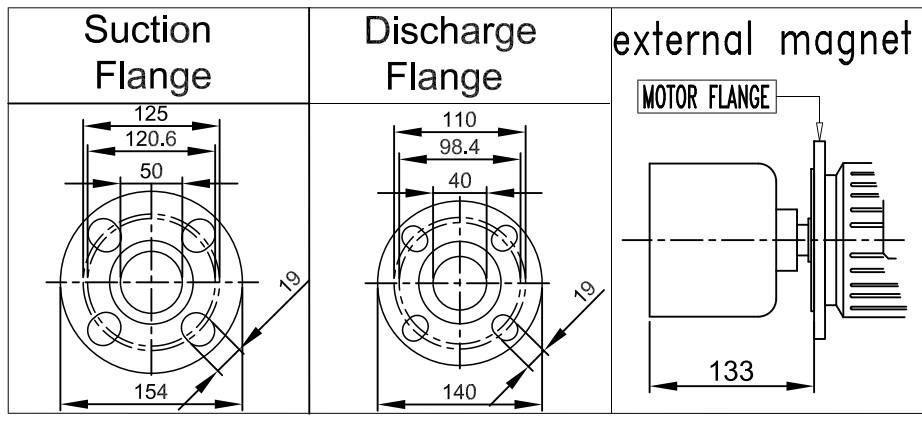

ITEM: Pump model: C MAG-P50 PP/PVDF

Motor: IEC Gr90 B5
 Port connection: Universal Flanged

OUTLINE DRAWING

CODE: D 10014 Rev.:00

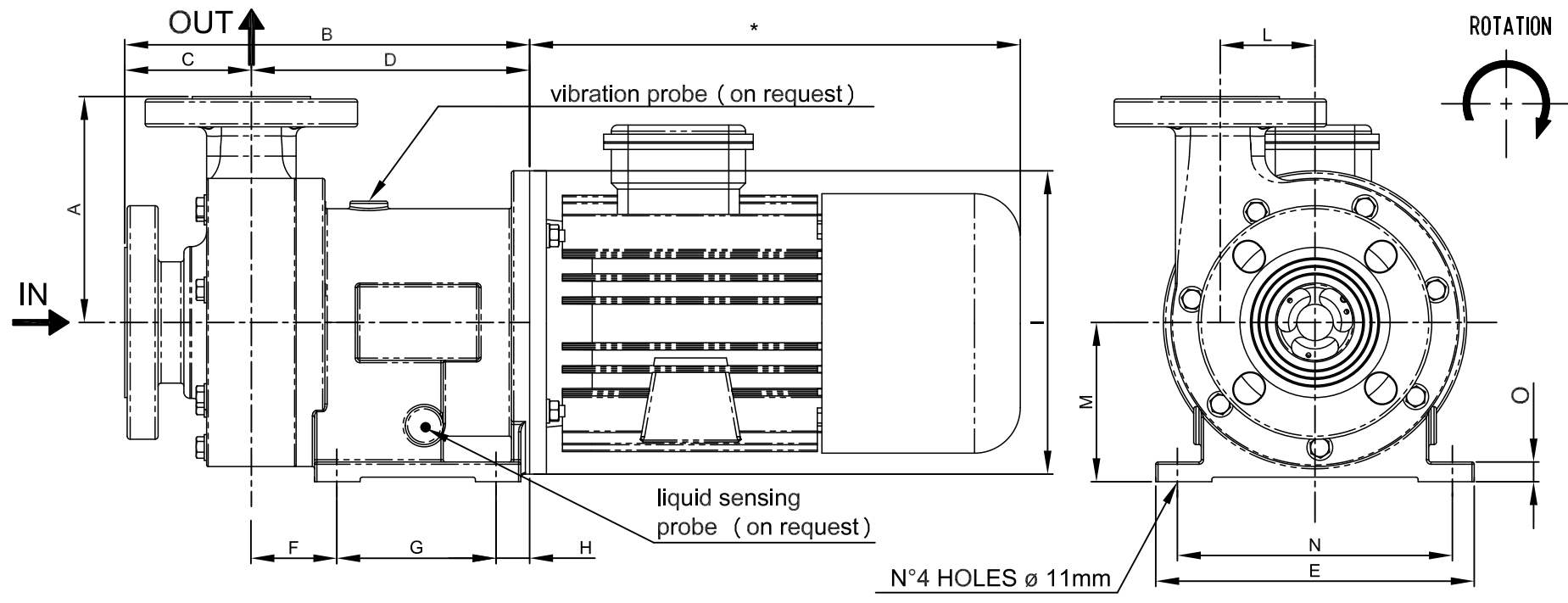

DIMENSIONS

A	B	C	D	E	F	G	H	I	L	M	N	O
149	277	83.5	193.5	220	52.5	120	21	250	62.5	135	180	15

- This drawing is for reference only
- Pump may be supplied without motor
- All dimensions are in millimeters

* Depend on the manufacturer

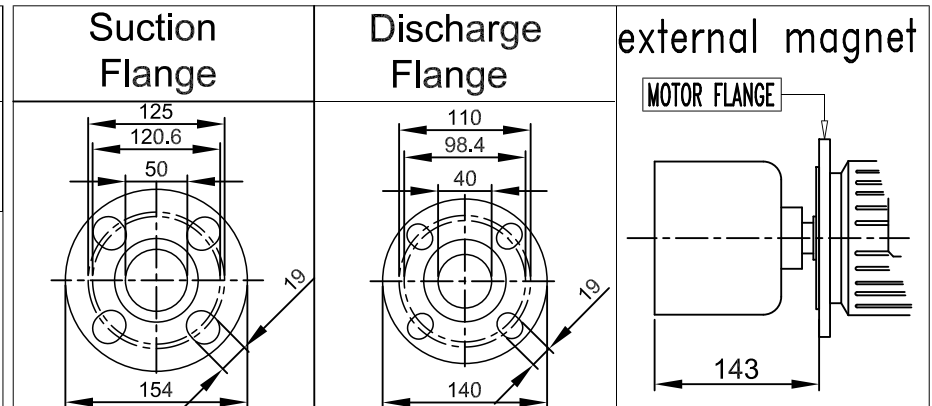

ITEM: Pump model: C MAG-P50 PP/PVDF

Motor: IEC Gr100 B5
 Port connection: Universal Flanged

OUTLINE DRAWING

CODE: D 10011 Rev.:00

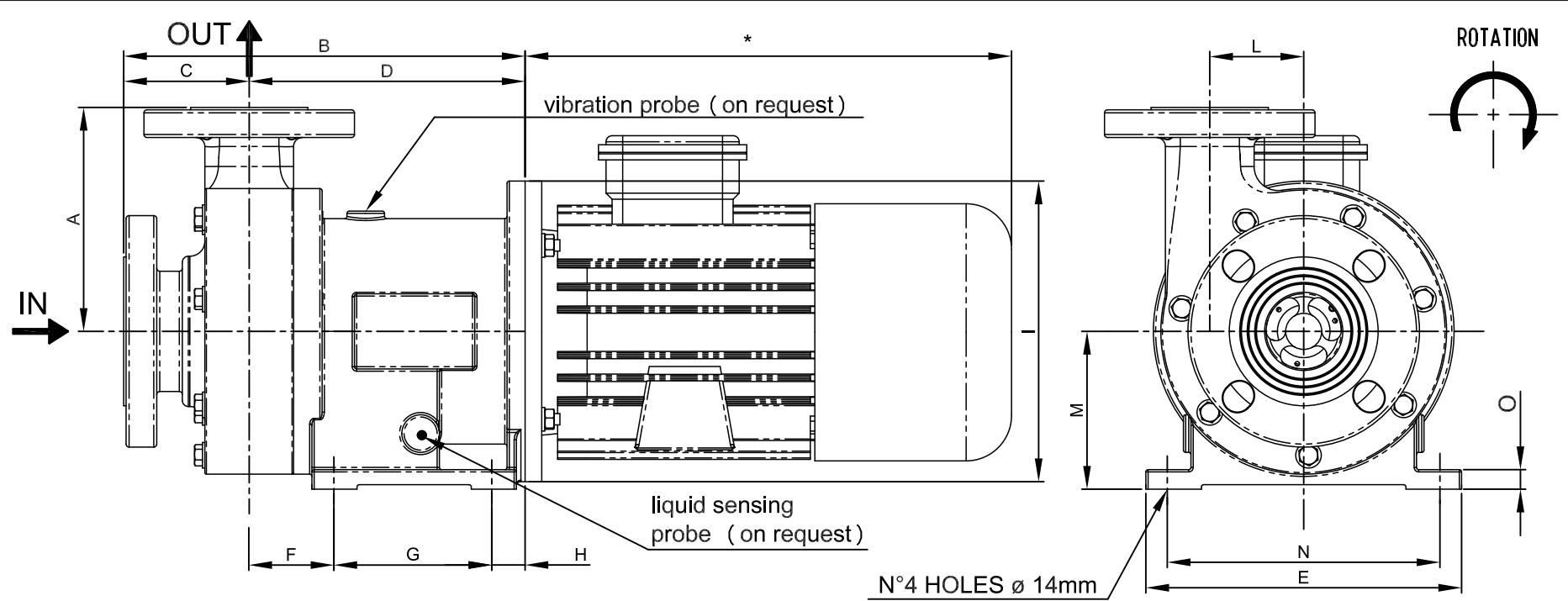

DIMENSIONS

A	B	C	D	E	F	G	H	I	L	M	N	O
171.5	320.5	103	217.5	250	80	100	37.5	250	73	135	210	15

- This drawing is for reference only
 - Pump may be supplied without motor
 - All dimensions are in millimeters

* Depend on the manufacturer

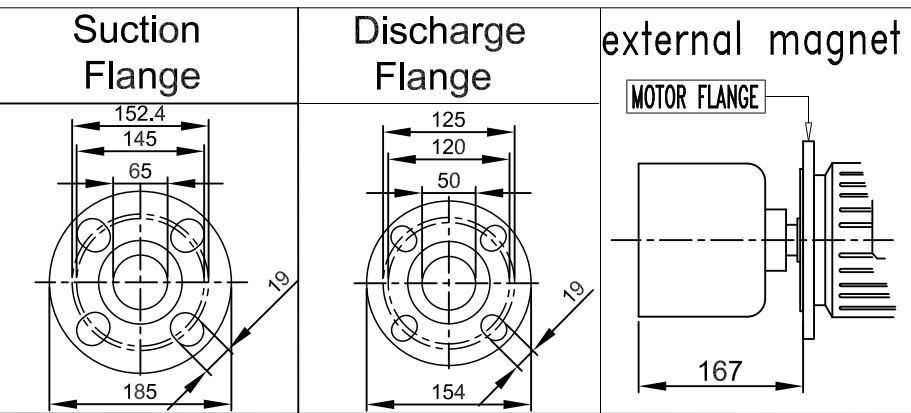

ITEM: Pump model: C MAG-865 PP/PVDF

Motor: IEC Gr100/112 B5
 Port connection: Universal Flanged

OUTLINE DRAWING

CODE: D 10013 Rev.:00

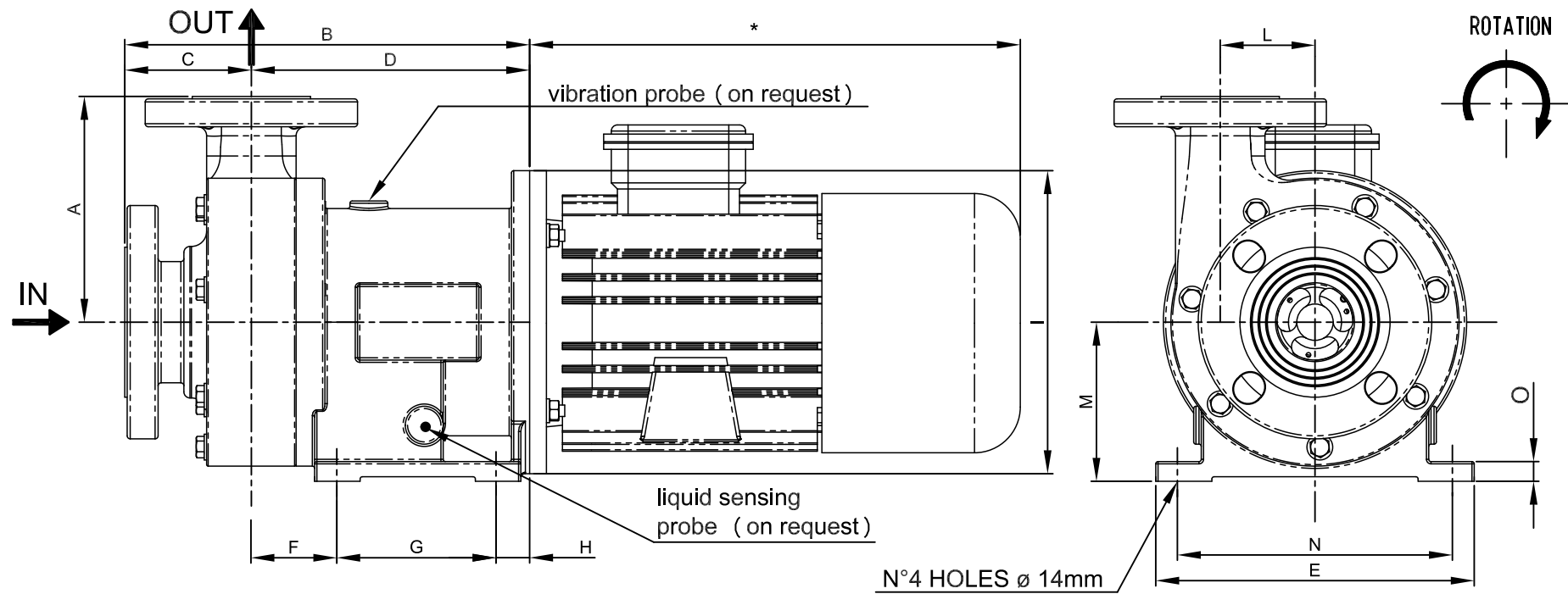

DIMENSIONS

A	B	C	D	E	F	G	H	I	L	M	N	O
171.5	340	103	237.5	250	80	120	37.5	300	73	153	210	15

- This drawing is for reference only
- Pump may be supplied without motor
- All dimensions are in millimeters

* Depend on the manufacturer

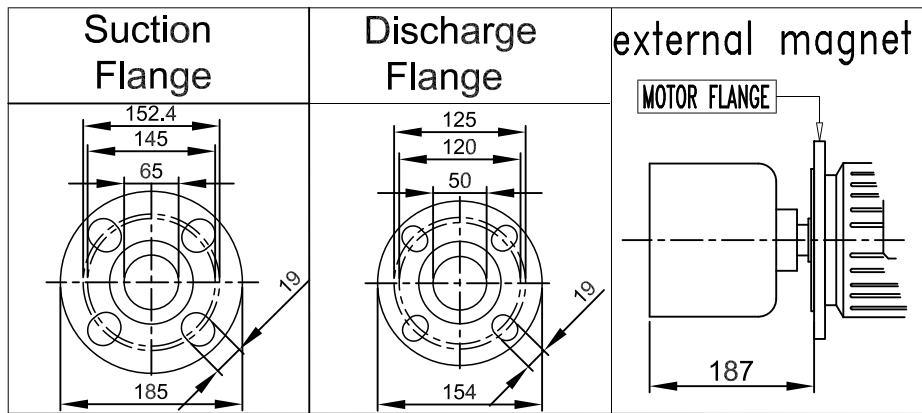

ITEM: Pump model: C MAG-065 PP/PVDF

Motor: IEC Gr132 B5
 Port connection: Universal Flanged

OUTLINE DRAWING

CODE: D 10012 Rev.:00

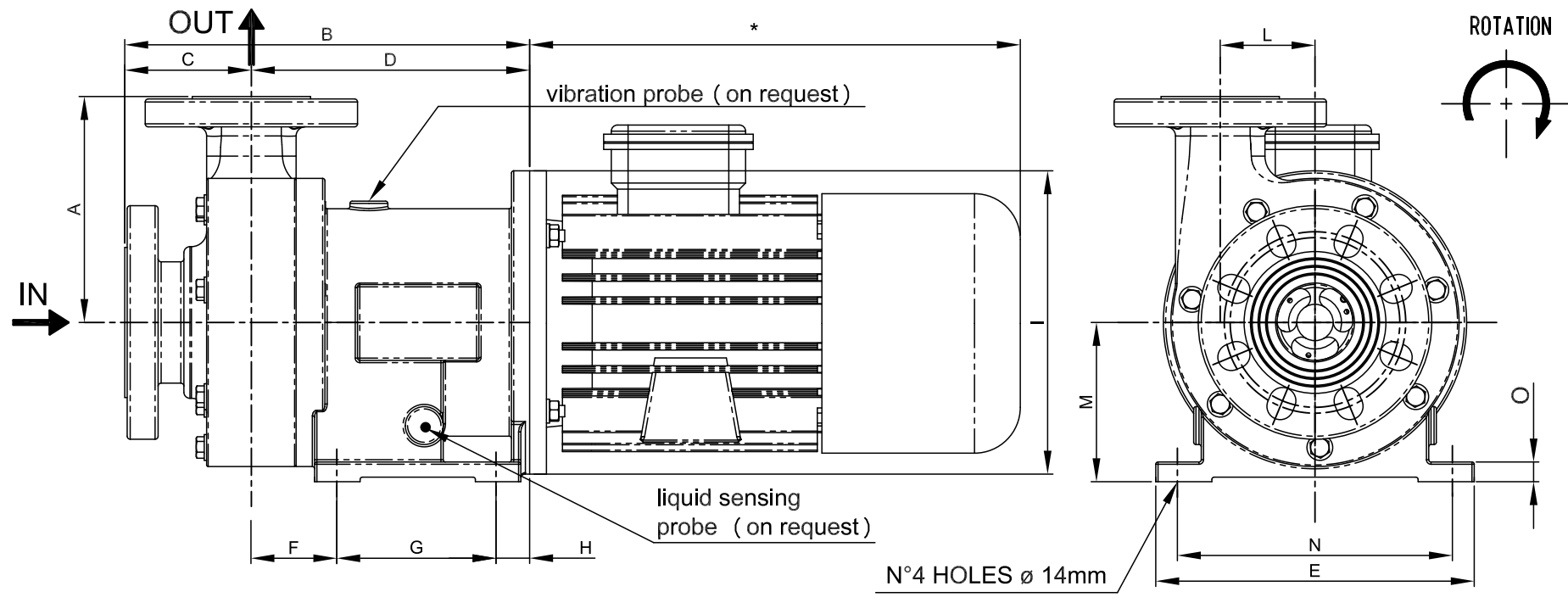

DIMENSIONS

A	B	C	D	E	F	G	H	I	L	M	N	O
198	367.5	121	246.5	250	89	120	37.5	300	82	153	210	15

- This drawing is for reference only
- Pump may be supplied without motor
- All dimensions are in millimeters

* Depend on the manufacturer

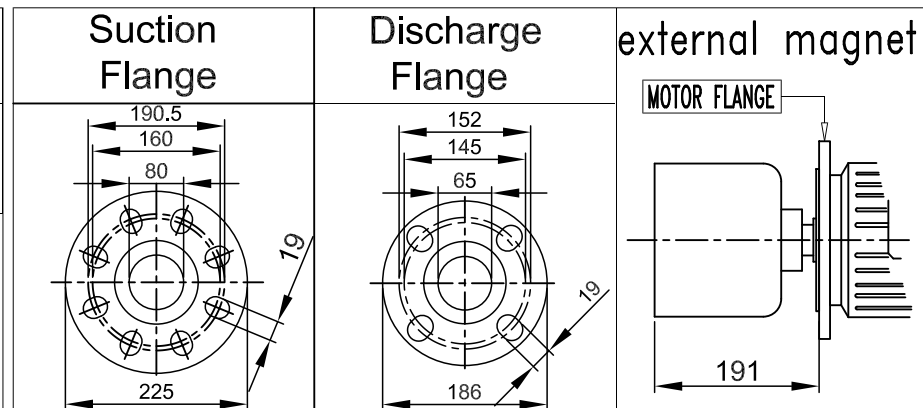

ITEM: Pump model: C MAG-P80 PP/PVDF

Motor: IEC Gr132 B5
 Port connection: Universal Flanged

OUTLINE DRAWING

CODE: D 10211 Rev.:00

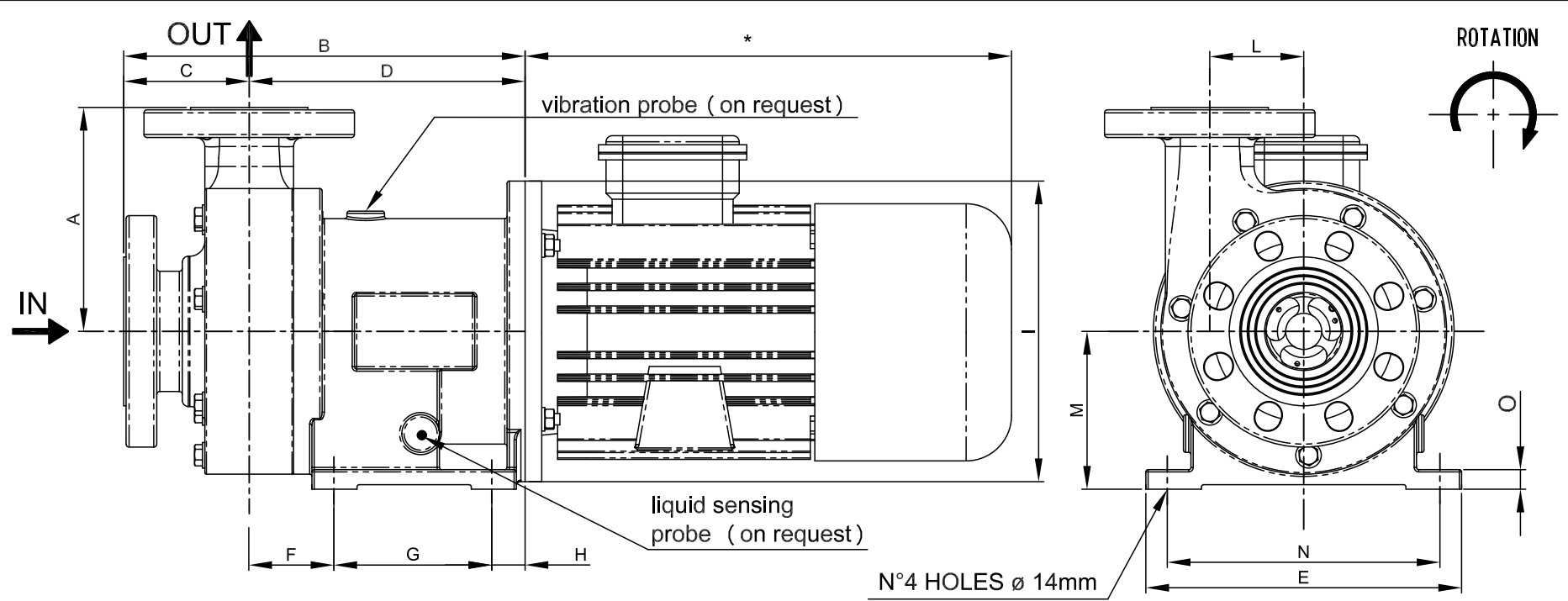

DIMENSIONS

A	B	C	D	E	F	G	H	I	L	M	N	O
227	408.5	128.5	280	290	92.5	150	37.5	350	102	180	250	20

- This drawing is for reference only
- Pump may be supplied without motor
- All dimensions are in millimeters

* Depend on the manufacturer

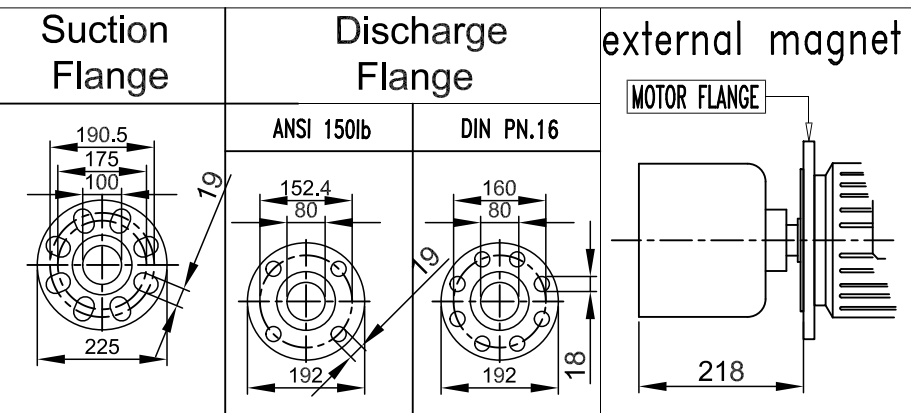

ITEM: Pump model: C MAG-P100 PP/PVDF

Motor: IEC Gr160 B5
Port connection: Universal Flanged